

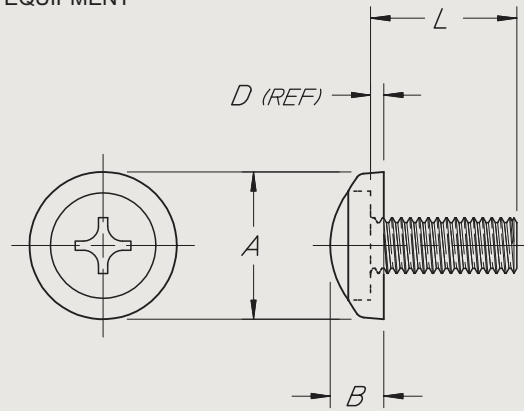

TYPICAL APPLICATION:  
SECURING PANELS AND RACK  
MOUNTED EQUIPMENT



DIMENSIONS ARE IN mm

©2002 DUPREE, INC.

PART NO. EXAMPLE: **MPS 5M 10 D S03GD** = METRIC PAN-L-SCREW, M5 X 0,8 X 10,0 STEEL, PHILLIPS DRIVE, SEMI-GLOSS CLOVE BROWN

HEAD TYPE	THREAD			L LENGTH						MATERIAL	COLOR CODE	DIM DATA ±0,50			
	CODE	NOMINAL DIAMETER	PITCH	TOL. ±0,3		TOL. ±0,4		TOL. ±0,5				A	B	D	
				8	10	13	16	20	25						
<b>MPS</b>	<b>25M</b>	2,5	0,45	<b>8</b>	<b>10</b>	<b>13</b>	<b>16</b>			<b>CP</b> CRES PHILLIPS DRIVE	SEE FORWARD SECTION FOR STOCK COLOR & CODE	7,0	2,96	0,86	
	<b>3M</b>	3,0	0,5	<b>8</b>	<b>10</b>	<b>13</b>	<b>16</b>					8,0	3,34	0,94	
	<b>35M</b>	3,5	0,6	<b>8</b>	<b>10</b>	<b>13</b>	<b>16</b>	<b>20</b>				9,5	3,62	1,02	
	<b>4M</b>	4,0	0,7	<b>8</b>	<b>10</b>	<b>13</b>	<b>16</b>	<b>20</b>	<b>25</b>			11,0	4,19	1,09	
	<b>5M</b>	5,0	0,8		<b>10</b>	<b>13</b>	<b>16</b>	<b>20</b>	<b>25</b>			13,0	4,86	1,16	
	<b>6M</b>	6,0	1,0			<b>13</b>	<b>16</b>	<b>20</b>	<b>25</b>			15,8	6,05	1,45	
										<b>D</b> STEEL PHILLIPS DRIVE					

**FEATURES:**

1. The one piece screw and captive washer simplifies handling, installation and removal of attachment hardware.
2. Attachment hardware, color matched with the mounting surface eliminates distraction from the information display by blending with the background.
3. Screw heads are formed by cold forging which increases the basic tensile strength of the material. The resultant high tensile strength thus eliminates burring and yield of the substrate under the coating material.
4. The thermosetting coating material used in combination with the relatively hard screw heads is resistant to abrasion and screw driver damage. This feature virtually eliminates the need for touch up painting after assembly.
5. The nylon washer provides a resilient cushion to protect the finished surface of panels and equipment.
6. A self-locking feature to prevent vibration from loosening the screw is achieved by the compression effect of the nylon washer between the screw head and the panel.
7. A seal for moisture, low pressure gases and vapors can be affected between the screw head and the panel surface by the compression of the nylon washer.

**NOTES:**

1. The screws listed in this series reflect high quality with emphasis on the forming of the Phillips recess to meet design specification.

2. Care should be exercised to assure that the screw driver tools meet the same quality and design specification in order to eliminate mismatching and subsequent damage to the drive recess and coating material.
3. The thread diameters and lengths listed in the table are industry standard sizes. Inventory levels of these sizes may vary at any one time due to customer demands and lead time necessary for production. Lengths not listed are also available on order.
4. For color coated screw less washer, order head type code "MSP".

**SPECIFICATIONS:**

1. Screws are in accordance with ANSI/ASME Standard No. B18.6.7M.
2. Screws with Material Code CP are 300 series corrosion resistant steel and are stocked passivated per QQ-P-35.
3. Screws with Material Code D are alloy steel and are stocked zinc plated in accordance with ASTM B633, Class SC1, Type II.
4. Pan-L-Screws are suitable for applications with temperatures up to 250°F.
5. Washer color is achieved by molding with pigmented nylon per ASTM D 4066-90.
6. Screw head coating and washer colors are matched to customer requirements. We recommend selection from Fed. Std. 595 whenever possible but we are also prepared to match customer furnished color chips or samples.

**STAKE FASTENER CO.**

14395 RAMONA AVENUE  
CHINO, CALIFORNIA 91710

(909) 597-4889  
CAGE 12324

FAX (909) 597-3043  
sales@stakefastener.com



**METRIC PAN-L-SCREW**  
COLORED HEAD, MACHINE THREAD,  
ALLOY STEEL