

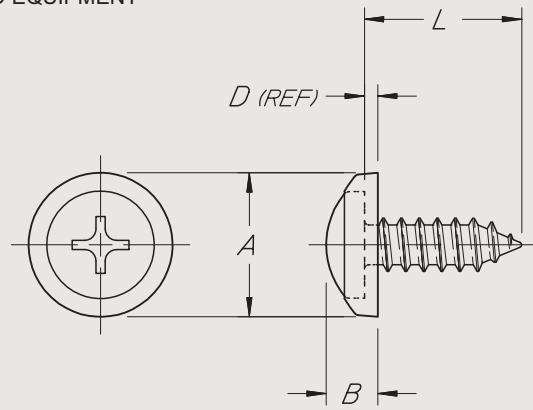

TYPICAL APPLICATION:
SECURING PANELS AND RACK
MOUNTED EQUIPMENT



©2002 DUPREE, INC.

PART NO. EXAMPLE: **PS 10SM 10 D S10GN** = PAN-L-SCREW, SHEET METAL, 10-16 X 5/8 LONG, STEEL, PHILLIPS DRIVE, SEMI-GLOSS PENINSULA GREEN

HEAD TYPE	THREAD			RECOMMENDED INSTALLATION HOLE SIZE	L LENGTH TOL. ±.03								MATERIAL	COLOR CODE	DIM DATA ±.020		
	CODE	NOMINAL DIAMETER	PITCH		1/4	3/8	1/2	5/8	3/4	7/8	1	A			B	D	
PS	4SM	4	24	.094	4	6	8	10	12			D STEEL PHILLIPS DRIVE	SEE FORWARD SECTION FOR STOCK COLOR & CODE	.312	.117	.037	
	6SM	6	20	.106	4	6	8	10	12	14	16			.375	.137	.040	
	8SM	8	18	.125		6	8	10	12	14	16			.438	.158	.043	
	10SM	10	16	.144		6	8	10	12	14	16			.500	.179	.046	

FEATURES:

- The one piece screw and captive washer simplifies handling, installation and removal of attachment hardware.
- Attachment hardware, color matched with the mounting surface eliminates distraction from the information display by blending with the background.
- Screw heads are formed by cold forging, followed by a case hardening and heat treating process which increases the basic tensile strength of the material. The resultant high tensile strength thus eliminates burring and yield of the substrate under the coating material.
- The thermosetting coating material used in combination with the relatively hard screw heads is resistant to abrasion and screw driver damage. This feature virtually eliminates the need for touch up painting after assembly.
- The nylon washer provides a resilient cushion to protect the finished surface of panels and equipment.
- A self-locking feature to prevent vibration from loosening the screw is achieved by the compression effect of the nylon washer between the screw head and the mounting surface.
- A seal for moisture, low pressure gases and vapors can be affected between the screw head and the mounting surface by the compression of the nylon washer.
- Type 'AB' thread style offers a fine pitch thread with a sharp gimlet point which aides entry of the Pan-L-Screw where hole misalignment could cause problems.

NOTES:

- The screws listed in this series reflect high quality with emphasis on the forming of the Phillips recess to meet design specification.
- Care should be exercised to assure that the screw driver tools meet the

same quality and design specification in order to eliminate mismatching and subsequent damage to the drive recess and coating material.

- The recommended installation hole sizes shown in the table are for light gage (.030) sheet metals. Compensation should be made for other materials and thicknesses. Refer to ANSI B18.6.4, Appendix VI.
- These Pan-L-Screws are capable of forming mating threads in steel plate with a maximum Rockwell hardness of B70-85 without thread shearing or breakage.
- These Pan-L-Screws are primarily intended for application in light sheet metal, plywood, certain plastics or material similar in composition where frequent removal is not necessary. They are not recommended for installation into brittle materials.
- Inventory of all sizes listed in the table and colors listed in the forward section of this catalog are carried in stock to assure prompt deliveries. Lengths not listed are also available on order.
- For color coated screw less washer, omit the letter **P** from the head type code.

SPECIFICATIONS:

- Screws are in accordance with ANSI/ASME Standard No. B18.6.4, Recessed Head Tapping Screws, Type AB.
- Screws are stocked zinc plated per ASTM B633, Class SC1, Type II.
- Washer color is achieved by molding with pigmented nylon per ASTM D 4066-90.
- Screw head coating and washer colors are matched to customer requirements. We recommend selection from Fed. Std. 595 whenever possible but we are also prepared to match customer furnished color chips or samples.

STAKE FASTENER CO.

14395 RAMONA AVENUE
CHINO, CALIFORNIA 91710
(909) 597-4889 FAX (909) 597-3043
CAGE 12324 sales@stakefastener.com



PAN-L-SCREW
COLORED HEAD, SHEET METAL THREAD,
ALLOY STEEL