

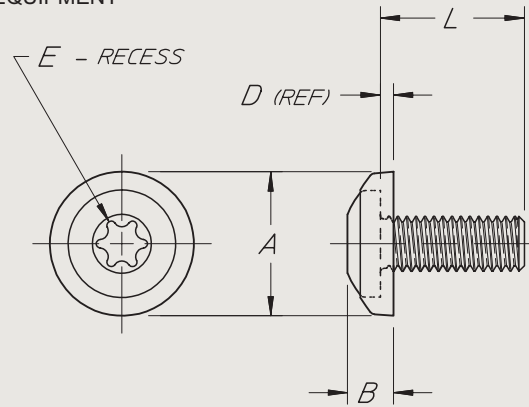

TYPICAL APPLICATION:  
SECURING PANELS AND RACK  
MOUNTED EQUIPMENT



©2002 DUPREE, INC.

PART NO. EXAMPLE: **PS 10F 10 DT S11BL** = PAN-L-SCREW .190-32 X 5/8 LONG, STEEL, TORX® RECESS, SEMI-GLOSS 132 DARK BLUE

HEAD TYPE	THREAD		L LENGTH													TOLERANCE	+ .00 - .03			+ .00 - .06			MATERIAL	COLOR CODE	DIM DATA ±.020			
	CODE	SIZE	3/16	1/4	5/16	3/8	7/16	1/2	9/16	5/8	11/16	3/4	7/8	1	1 1/8		1 1/4	A	B	D	E							
<b>PS</b>	<b>2C</b>	.086-56 UNC-2A	3	4	5	6	7	8												.250	.096	.034	T8					
	<b>4C</b>	.112-40 UNC-2A	3	4	5	6	7	8	9	10	11	12	14	16						.312	.117	.037	T10					
	<b>6C</b>	.138-32 UNC-2A	3	4	5	6	7	8	9	10	11	12	14	16						.375	.137	.040	T15					
	<b>8C</b>	.164-32 UNC-2A	3	4	5	6	7	8	9	10	11	12	14	16						.438	.158	.043	T20					
	<b>10F</b>	.190-32 UNF-2A		4	5	6	7	8	9	10	11	12	14	16	18	20				.500	.179	.046	T25					
	<b>12C</b>	.216-24 UNC-2A					7	8	9	10	11	12	14	16	18	20				.562	.201	.050	T27					
	<b>14C</b>	.250-20 UNC-2A						8	9	10	11	12	14	16	18	20				.625	.232	.057	T30					

**FEATURES:**

- The one piece screw and captive washer simplifies handling, installation and removal of attachment hardware.
- Attachment hardware, color matched with the mounting surface eliminates distraction from the information display by blending with the background.
- Screw heads are formed by cold forging, followed by a heat treating process which increases the basic tensile strength of the material. The resultant high tensile strength thus eliminates burring and yield of the substrate under the coating material.
- The thermosetting coating material used in combination with the relatively hard screw heads is resistant to abrasion and screw driver damage. This feature virtually eliminates the need for touch up painting after assembly.
- The nylon washer provides a resilient cushion to protect the finished surface of panels and equipment.
- A self-locking feature to prevent vibration from loosening the screw is achieved by the compression effect of the nylon washer between the screw head and the panel.
- A seal for moisture, low pressure gases and vapors can be affected between the screw head and the panel surface by the compression of the nylon washer.

**NOTES:**

- TORX® is a registered trademark of Camcar Textron.
- The screws listed in this series reflect high quality with emphasis on the forming of the TORX® recess to meet design specification.

- Care should be exercised to assure that the screw driver tools meet the same quality and design specification in order to eliminate mismatching and subsequent damage to the drive recess and coating material.
- The thread diameters and lengths listed in the table are industry standard sizes. Inventory levels of these sizes may vary at any one time due to customer demands and lead time necessary for production. Lengths not listed are also available on order.
- For color coated screw less washer, omit the letter **P** from the head type code.

**SPECIFICATIONS:**

- Screws are in accordance with ANSI/ASME Standard No. B18.6.3, Recessed Head Machine Screws.
- Screws are stocked zinc plated per ASTM B633, Class SC1, Type II.
- Threads are in conformance with H-28 Federal Handbook for threads.
- Pan-L-Screws are suitable for applications with temperatures up to 250°F.
- Washer color is achieved by molding with pigmented nylon per ASTM D 4066-90.
- Screw head coating and washer colors are matched to customer requirements. We recommend selection from Fed. Std. 595 whenever possible but we are also prepared to match customer furnished color chips or samples.

**STAKE FASTENER CO.**  
14395 RAMONA AVENUE  
CHINO, CALIFORNIA 91710  
(909) 597-4889 FAX (909) 597-3043  
CAGE 12324 sales@stakefastener.com



**PAN-L-SCREW**  
COLORED HEAD, MACHINE THREAD,  
ALLOY STEEL, TORX® RECESS