

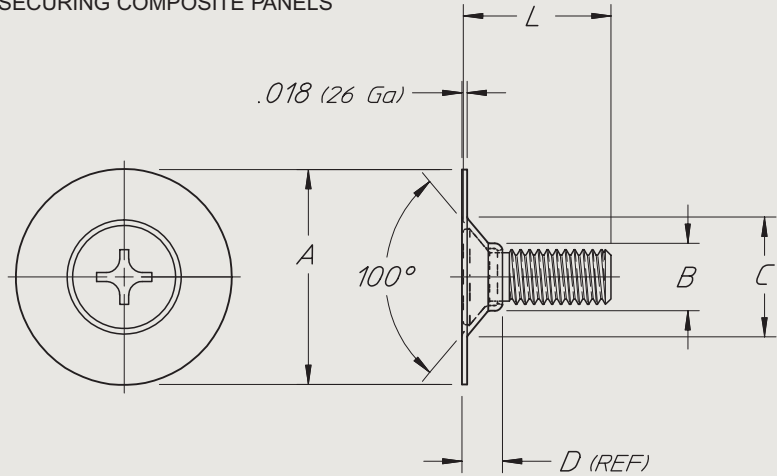

TYPICAL APPLICATION:
SECURING COMPOSITE PANELS



©2002 DUPREE, INC.

PART NO. EXAMPLE: **FCM 10F 14 CP S13BN** =

100° FLAT HEAD SCREW w/CAPTIVE METAL WASHER,
.190-32 X 7/8 LONG, COR. RES. STEEL, PHILLIPS DRIVE,
SEMI-GLOSS BROWN PER FED. STD. 595 NO. 20122

HEAD TYPE	THREAD		L LENGTH								TOLERANCE +.00 -.03	MATERIAL	COLOR CODE	DIM DATA ±.02			
	CODE	SIZE	1/4	5/16	3/8	7/16	1/2	5/8	3/4	7/8				1	A	B	C
FCM	10F	.190-32 UNF-2A	4	5	6	7	8	10	12	14	16	CP CRES PHILLIPS DRIVE	SEE FORWARD SECTION FOR STOCK COLOR & CODE	.75	.23	.41	.15

FEATURES:

1. The one piece screw and captive washer simplifies handling, installation and removal of attachment hardware.
2. Attachment hardware, color matched with the mounting surface eliminates distraction from the information display by blending with the background.
3. Screw heads are formed by cold forging which increases the basic tensile strength of the material. The resultant high tensile strength thus eliminates burring and yield of the substrate under the coating material.
4. The thermosetting coating material used in combination with the relatively hard screw heads is resistant to abrasion and screw driver damage. This feature virtually eliminates the need for touch up painting after assembly.
5. The metal washer provides a low profile bearing surface to protect the finished surface of panels and equipment.

NOTES:

1. The screws listed in this series reflect aircraft quality with emphasis on the forming of the Phillips recess to meet design specification.
2. Care should be exercised to assure that the screw driver tools meet the same quality and design specification in order to eliminate mismatching and subsequent damage to the drive recess and coating material.

3. The thread diameters and lengths listed in the table are industry standard sizes. Inventory levels of these sizes may vary at any one time due to customer demands and lead time necessary for production. Lengths not listed are also available on order.

SPECIFICATIONS:

1. Screw and washer material is 300 series corrosion resistant steel (Cres).
2. Screws and washers are passivated per QQ-P-35.
3. Threads are in conformance with H-28 Federal Handbook for threads.
4. Screw head coating and washer colors are matched to customer requirements. We recommend selection from Fed. Std. 595 whenever possible but we are also prepared to match customer furnished color chips or samples.

STAKE FASTENER CO.
14395 RAMONA AVENUE
CHINO, CALIFORNIA 91710
(909) 597-4889 FAX (909) 597-3043
CAGE 12324 sales@stakefastener.com



SCREW
COLORED 100° FLAT HEAD
w/CAPTIVE LARGE O.D. METAL WASHER,
MACHINE THREAD, CRES