

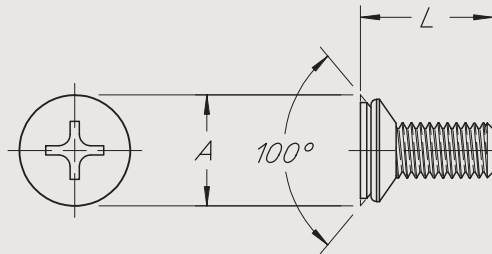

TYPICAL APPLICATION:
SECURING PANELS WHERE A
LIQUID-TIGHT SEAL IS DESIRED.

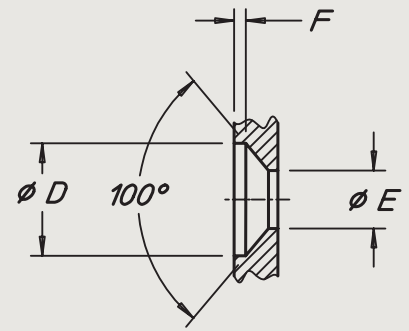

**RECOMMENDED
CLEARANCE HOLE**



©2002 DUPREE, INC.

PART NO. EXAMPLE: **FHW 10F 7 D S34GY** = 100° FLAT HEAD SCREW w/CAPTIVE NYLON SEALING WASHER, .190-32 X 7/16 LONG, STEEL, PHILLIPS DRIVE, SEMI-GLOSS SEAFOAM GRAY

HEAD TYPE	THREAD (SEE SPECIFICATION FOR CLASS OF THREAD FIT)		L LENGTH TOLERANCE $\begin{matrix} +.00 \\ -.03 \end{matrix}$							MATERIAL	COLOR CODE	DIMENSIONAL DATA			
	CODE	SIZE	$\frac{3}{8}$	$\frac{7}{16}$	$\frac{1}{2}$	$\frac{5}{8}$	$\frac{3}{4}$	$\frac{7}{8}$	1			A <small>SHARP</small>	D	E	F
FHW	10F	.190-32 UNF	6	7	8	10	12	14	16	CP CRES PHILLIPS DRIVE D STEEL PHILLIPS DRIVE	SEE FORWARD SECTION FOR STOCK COLOR & CODE	.385	.391	.201	.040

FEATURES:

1. Screws are furnished with captive nylon sealing washer and when installed in recommended clearance hole this assembly provides a liquid-tight seal.
2. Screws are furnished with pre-colored heads to match panels and equipment. The coating material used in combination with the relatively hard screw heads is resistant to abrasion and screw driver damage. This feature virtually eliminates the need for touch up painting after assembly.
3. The thermosetting coating material is both abrasion and solvent resistant. Screw heads are cleaned and prepared for maximum adhesion of the coating material.
4. Screw heads are formed by cold forging which increases the basic tensile strength of the material. The resultant high tensile strength thus eliminates burring and yield of the substrate under the coating material.

NOTES:

1. The screws listed in this series reflect aircraft quality with emphasis on the forming of the Phillips recess to meet design specification.
2. Care should be exercised to assure that the screw driver tools meet the same quality and design specification in order to eliminate mismatching and subsequent damage to the drive recess and coating material.

3. The thread diameters and lengths listed in the table are industry standard sizes. Inventory levels of these sizes may vary at any one time due to customer demands and lead time necessary for production. Lengths not listed are also available on order.

SPECIFICATIONS:

1. Screws with material code **CP** meet all requirements of MS24693. Material is 300 series corrosion resistant steel. Screws are passivated per QQ-P-35. Screws of this material have a class 2A thread fit per FED-STD-H28/2.
2. Screws with material code **D** meet all requirements of NAS514. Screws are stocked cadmium plated per QQ-P-416, Type II, Class 2. Screws of this material have a class 3A thread fit per MIL-S-8879.
3. Washer color matches screw head color and is achieved by molding with pigmented nylon per ASTM D4066.
4. Coating colors are matched to customer requirements. We recommend selection from Fed. Std. 595 whenever possible but we are also prepared to match customer furnished color chips or samples.
5. For an assembly with uncoated screw and natural colored sealing washer, order color code **N02NA**.

STAKE FASTENER CO.

14395 RAMONA AVENUE
CHINO, CALIFORNIA 91710

(909) 597-4889
CAGE 12324

FAX (909) 597-3043
sales@stakefastener.com



SEALING SCREW

COLORED 100° FLAT HEAD,
w/CAPTIVE NYLON WASHER
MACHINE THREAD, ALLOY STEEL