

Pressure Displacement Fasteners

Installation Guidelines

The type “Basic”, “BA”, and “BB” fasteners are designed to be installed using standard presses (mechanical, hydraulic, or impact) commonly found in a shop environment. The tooling required is simply a punch and an anvil which can be installed in the press to be used. For the type “Basic” fastener, both the punch and anvil are flat. For the type “BA” and “BB” fasteners, a clearance hole (F & G dimensions) is required in the punch for the appendage. See

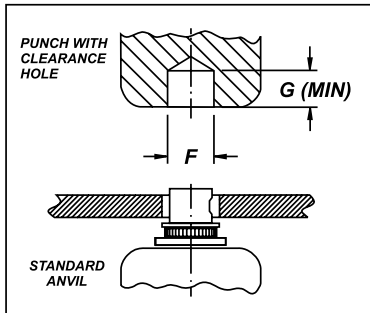

Table 1 below for recommended punch clearance hole size. Due to the wide variety of press equipment available and the simplicity of the punch and anvil required, it is intended that customers fabricate their own

punch and anvil to fit their particular equipment and applications.

THREAD		APP DIA	TOOLING CLEARANCE HOLE		
CODE	SIZE	∅D	∅F	G	
2C	.086-56UNC-3B	.110	.1200	#31	.20
4C	.112-40UNC-3B	.139	.1470	#26	.23
6C	.138-32UNC-3B	.165	.1719	11/64	.26
8C	.164-32UNC-3B	.204	.2090	#4	.26
10F	.190-32UNF-3B	.229	.2344	15/64	.29
14F	.250-28UNF-3B	.300	.3125	5/16	.29

To install the fastener, a mounting hole must be punched or machined into the sheet per dimension ‘E’, shown on the part specifications. It is not necessary nor recommended that the mounting hole be deburred prior to installation. Place the sheet material with the mounting hole centered over the flat anvil. Locate the fastener with the small flange diameter towards the sheet (see Figure, INSERT) and centered over the mounting hole. Lower the punch over the fastener and locate the fastener appendage into the clearance hole for type ‘BA’ and ‘BB’ fasteners (see Figure, STAKE). Apply pressure between the punch and anvil to force the fastener into the sheet until the grip areas

are flush with both surfaces of the sheet (see Figure, INSTALLED). This staking process should be performed in one continuous motion for best results. The amount of pressure to be applied will vary with fastener size, sheet thickness, and type of material used.

